



141-QH03

IGM Magnetic Base for M3 Feeder

Manual



Distributor
IGM nástroje a stroje s.r.o.
Ke Kopanině 560, 252 67, Tuchoměřice
Czech Republic, EU
Phone: +420 220 950 910
E-mail: sales@igmtools.com
Website: www.igmtools.com

2024-03-08

141-QH03 IGM Magnetic Base for M3 Feeder Manual EN v1.01.02 A4ob



EN – English Manual

Dear Customer,

thank you for the confidence you have placed in us with the purchase of your new IGM accessory. This manual was prepared for the owner and operator of **IGM Magnetic Base for M3 Feeder** to promote safety during setup, operation and maintenance. Please read carefully and understand the information contained in this manual and accompanying documents. To obtain maximum service life and performance, use the accessory according to these instructions and safety guidelines. Observe work safety.

We wish you a lot of work satisfaction and joy when working with the IGM Magnetic Base for M3 Feeder.

Contents

1. Warranty

2. Specification

3. Safety

3.1 Intended Use

3.2 General Safety Instructions

3.3 Symbols

3.4 Additional Safety Instructions for Accessory

3.5 Environment

4. Accessory Description

4.1 Package Contents

4.2 Unpacking

4.3 Assembly

4.4 Operation

5. Maintenance and Cleaning

6. Accessories and Compatibility

7. Parts List

1. Warranty

IGM always strives to deliver a high-quality and efficient product. The warranty is governed by the valid terms and conditions of IGM.

2. Specification

Dimensions (LxWxH):	367 x 231 x 136 mm
Weight:	5,4 kg
Package Dimensions (LxWxH):	420 x 300 x 177 mm
Package Weight:	7,4 kg
Magnet size (1pc):	Ø60 x Ø8,5 x 15 mm
Maximum Magnet Force (3pcs):	450 kg
Maximum Material Thickness:	40 mm
Minimum Material Width after Cutting:	45 mm

3. Safety

Proper use includes compliance with the instructions given in this manual. The accessory may be operated only by a person familiar

with the instructions given in this manual and machine operation. The accessory may be used only in a perfect technical condition.

When working, all safety covers must be mounted. In addition to instructions given in this manual, always follow general

regulations applicable in your country. The operator is liable for improper or unauthorized use.

3.1 Intended Use

This accessory is designed only for mounting M3 feeder to a cast iron or steel table. Do not use with other feeders.

3.2 General Safety Instructions

Warning! Read all instructions and safety guidelines. Failure to follow safety instructions may result in damage to the accessory and serious injury to the operator. Keep the manual for future reference.

- The accessory may be dangerous if not used properly. Read the manual carefully and make sure you understand all the instructions.
- Keep children and pets away from packaging materials.
- Use the accessory on a stable and well-lit surface. There must be sufficient space around the accessory for safe operation.
- Check the technical condition of the accessory and its parts before work. The accessory must be free from damage. Do not use the accessory if any damage is found. Replace damaged parts immediately. Use only original spare parts.
- All safety covers must be mounted before operation. Replace damaged covers immediately.
- The accessory may be used, assembled, and maintained only by persons who are familiar with its operation and are aware of potential danger. No changes to the accessory may be made!
- Carry out maintenance regularly.
- Carry out assembly, repairs, maintenance, and tool replacement only when the machine used with this accessory is disconnected from the power supply.
- Prevent unintentional start-up. Before connecting the machine to the power supply, make sure the switch is in OFF position.
- Take care of your safety when working. Long hair, loose clothing and jewellery may cause injury. Wear suitable work clothing, footwear and eye, ear and respiratory protection.
- Do not work with the accessory if you feel tired, ill or under the influence of drugs or alcohol.
- Watch your hands and fingers. Always use both hands when working.
- Always maintain balance and stand on firm and stable surface when working.
- Keep children and other persons from moving freely around the workplace. Keep the accessory out of reach of children and unqualified persons. Do not allow anyone who is not familiar with the accessory and this manual to use the accessory.
- Do not leave the accessory in a damp environment and do not expose it to rain.
- Do not operate the accessory near flammable liquids or gases.

3.3 Symbols



Do not put your hands under the base!



Do not use with pacemaker!



Scan the QR code to find the manual



Recycle package materials



Do not dispose of the device in the municipal waste

3.4 Additional Safety Instructions for Accessory

- Always make sure that the base is firmly attached.
- Do not put your fingers under the base! You risk pinching your fingers.
- The base has strong magnets. Accidental connection to a magnetic surface may result in injury.
- The base should be kept away from easily magnetized objects, such as pacemakers, credit cards, computers, televisions, etc.
- Maximum temperature resistance is 80° C. It is recommended to use the magnet in conditions below 70°C.
- Use the base in suitable environment only. In regular conditions, the magnet will retain its magnetic properties. Extreme conditions may lead to complete loss of magnetism.
- The base may be attached to cast iron or steel tables only.
- The magnet is hard but brittle. Avoid heavy impact, the magnet may be damaged.
- Peeling of the plating of the magnet has no effect on use and strength of the magnet.

3.5 Environment

If possible, do not dispose of the accessory in the municipal waste. Recycle the accessory and package material.

4. Accessory Description

Carefully observe the images below and familiarize yourself with the package contents and listed parts and features.

4.1 Package Contents



Magnetic Base
Locking Handle
4x Screw M10
4x Spring Washer

4.2 Unpacking

When unpacking, separate the accessory and all supplied parts from the packaging materials. Check that no parts have been

damaged. If damage has occurred as a result of transport, contact your supplier immediately.

1. Grab the base by the handle to pull it out of the box. Place it on a non-magnetic surface or a thick insulating material.

4.3 Assembly



Tools needed: wrench 17mm

1. Secure the locking handle (A) on the locking screw (B). Use the 17mm wrench to tighten the hex nut (C) and secure it to the handle.

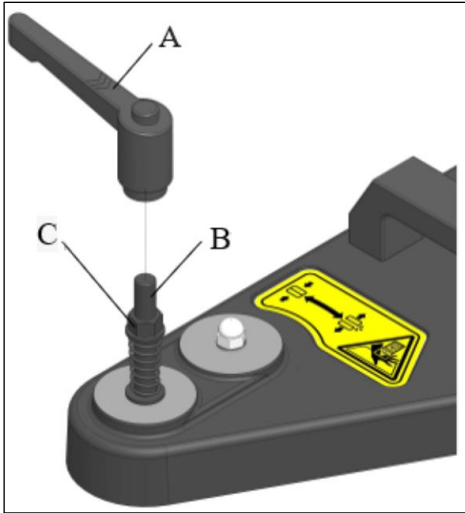

2. Rotate the locking handle (A) to protrude the locking screw (B). Now move the base to a suitable spot.

Caution! If the base is not attached, leave the locking screw extended as shown. This will prevent accidental connection to a magnetic surface.

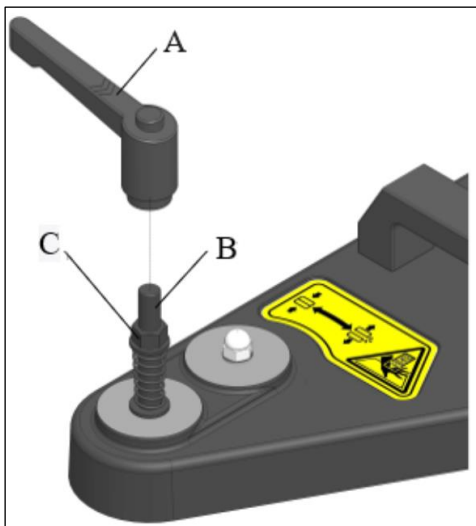

3. Disconnect the machine from the power supply! Remove blade guard (A) from the table saw and lower the saw blade (B) into the table.

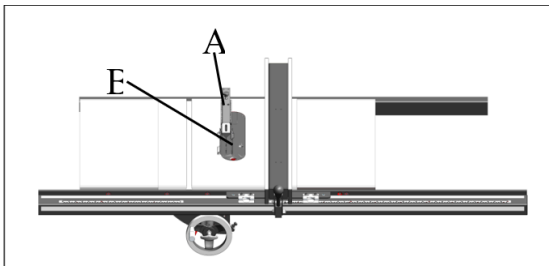

4. Adjust the rip fence (A) according to material size and place the magnetic base to the right of the feed direction (B). Before placing the base, check that the locking screw is extended.

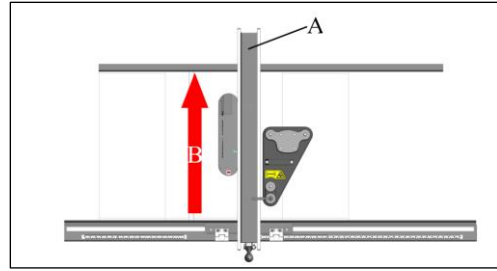

5. After placing the base in a suitable spot, rotate the locking handle until the locking screw is completely retracted. Check by hand that the base is securely attached.

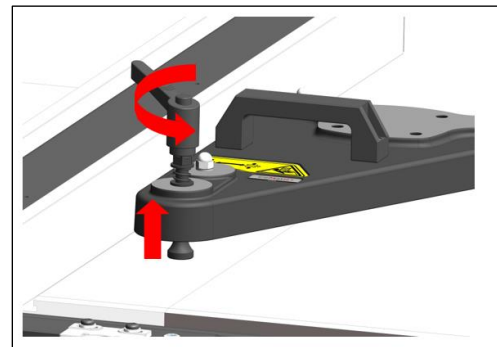

6. Use four screws M10 and four spring washers (B) to mount the feeder base (A) to the magnetic base. Use all four screws and washers to mount the base.

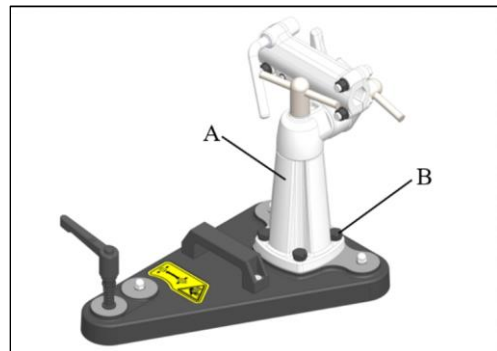

7. Insert feeder arm (A) in the arm holder (B).



4.4 Operation



1. Adjust feeder position so that feed rollers (B) are between the blade (A) and the rip fence (C).

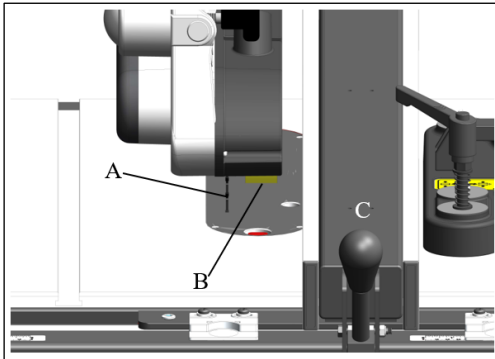

2. The feed roller should extend beyond the saw blade edge at the feed entry (C). The material must first touch the roller (B), then the blade (A).

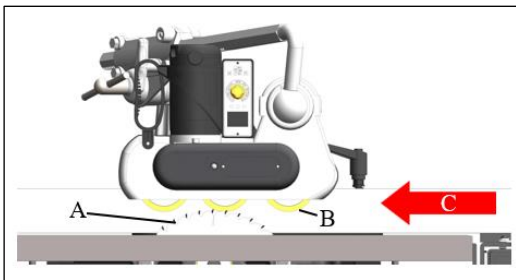

3. To feed the material correctly, the distance between the infeed roller (B) and fence should be 3 - 5 mm greater than the distance between outfeed roller (A) and fence.

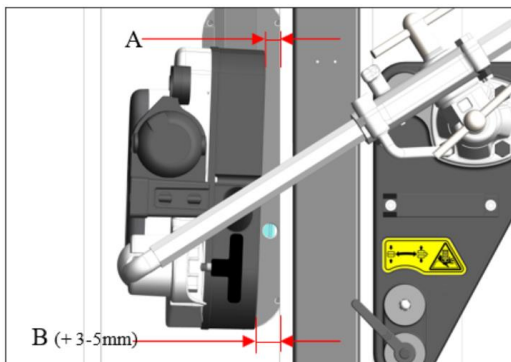

4. Lower the blade into the table and check that all rollers are in contact with the material. This will ensure smooth feeding. Do not exert too much pressure on the material, it may cause the base to shift.

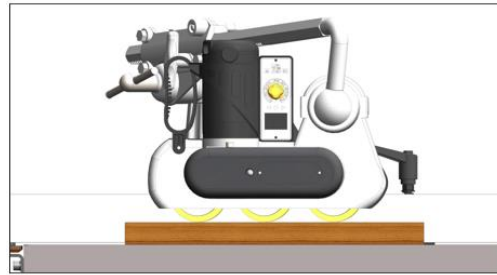

5. Connect the feeder to the power supply and confirm correct feeding.

6. Adjust saw blade according to material thickness. The blade must not exceed material thickness by more than 3 mm, otherwise the feeder and its parts may be damaged.

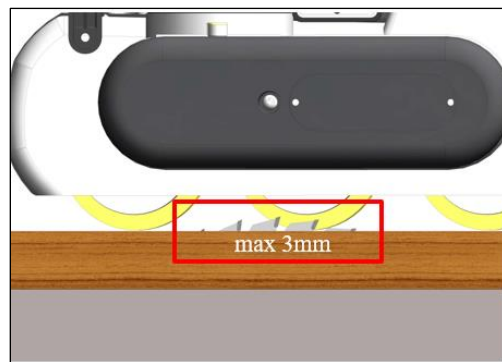

7. Outline the position of the attached base with a marker. It allows you to check whether the base has shifted.

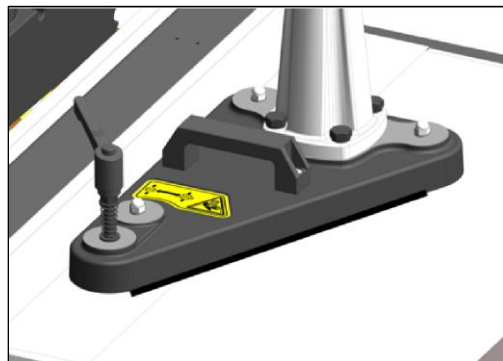

8. To move the base with mounted feeder, rotate the locking handle and lift the base from table surface.

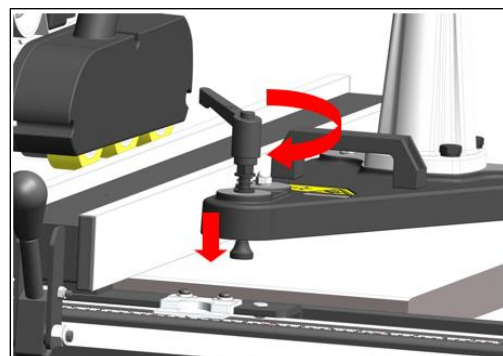

9. Grab the feeder arm (A) and handle on the base (B). Move the base with mounted feeder.

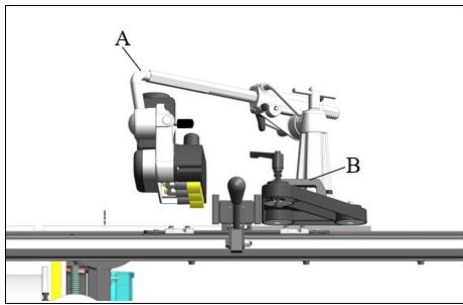

Recommendations and Limits

Material width after cutting should not exceed 230 mm if the magnetic base is attached at the edge of the table. Maximum width may also vary depending on specifications of your table saw.

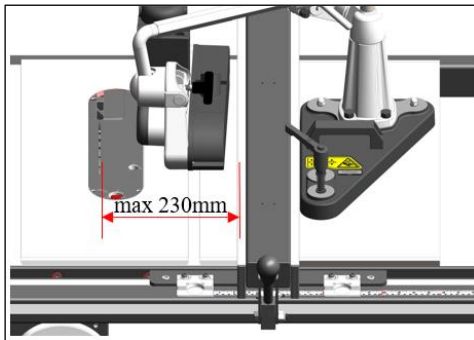

Minimum material width after cutting is 45 mm, otherwise the roller may be damaged.

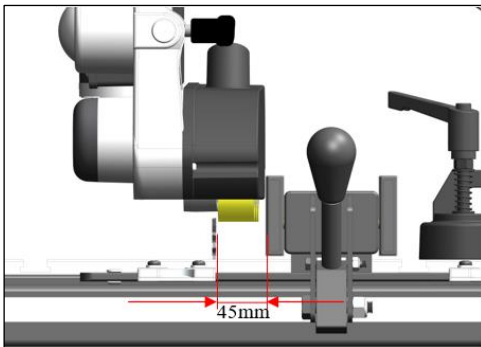

It is recommended using material 40 mm wide at maximum to avoid excessive resistance that may cause the base to shift and be unstable. Excessive resistance can be avoided by reducing saw blade speed or feed rate as well.

5. Maintenance and Cleaning



Caution! Disconnect the machine from the power supply before maintenance and cleaning. Carry out maintenance regularly.

Before each use, check for loose screws or parts and any damage. Do not use the accessory until all defects have been fixed.

After each use, vacuum dust and other scraps from the accessory, machine, and surrounding area. Wipe with a dry cloth. If resin has built up, use resin remover.

Regularly apply a layer of anti-corrosion oil on the mounting plate, locking screw and magnets from both sides. These parts are highlighted in gray.

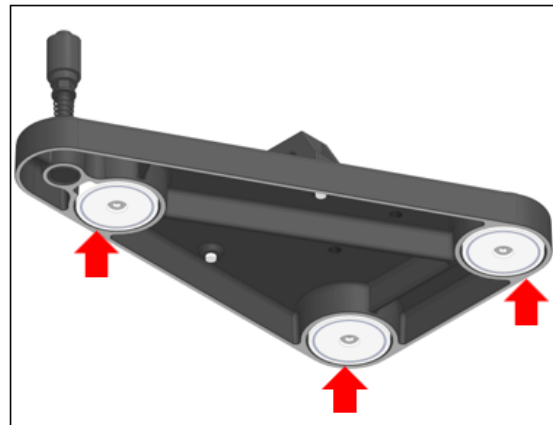
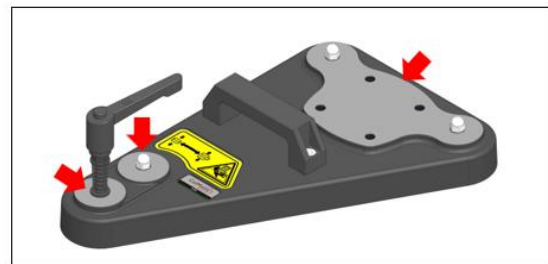

6. Accessories and Compatibility

Recommended accessories and compatibility is listed on the IGM website.

Caution! Installing unapproved accessories can cause damage to the machine and serious injury. Use this accessory only with machines designed for it.

7. Parts List

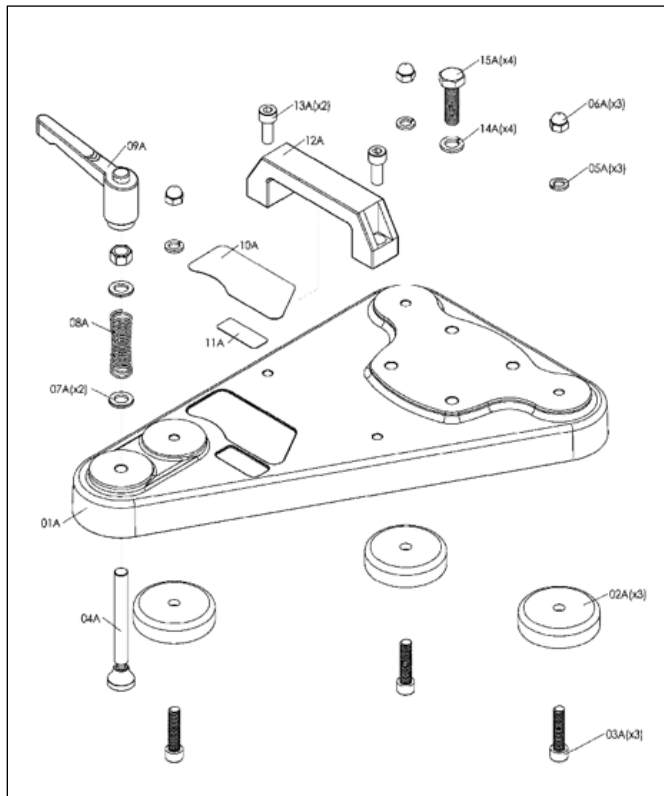

Part No.	Code No.	Description	Q'ty
01A	A250015	Baseplate	1
02A	C300006	Magnets	3
03A	S900835-002	Round Head Hex Screw	3
04A	G000072	Universal Level Adjuster (Include Nut)	1
05A	N030008	Spring Washer	3
06A	N13008R-001	Hexagon Nut	3
07A	N011019	Washer	2
08A	N930047	Spring	1
09A	T060036	Universal Handle	1
10A	P200214	Warning Sticker	1
11A	P200215	Name Plate	1
12A	U010359	U Handle	1
13A	S900820-002	Round Head Hex Screw	2
14A	N030010	Spring Washer	4
15A	S601035	Hex Screw	4